



# Aluminum Hydraulic Vertical Shoring

HYDRAULIC CYLINDER  
**PRO-TEC** CYLINDER  
MS-C-3455  
34"-55"  
1-800-222-1988

HYDRAULIC CYLINDER  
**PRO-TEC** CYLINDER  
MS-C-3455  
34"-55"  
1-800-222-1988



# PRO-TEC Lightweight Aluminum Vertical Shores:

**exceptionally strong, durable, portable, versatile**

- ▼ High yield aluminum alloy construction makes PRO-TEC shores light in weight yet extra strong for long lasting durability.
- ▼ Cylinder pads mount flush, providing even load distribution on side rails.
- ▼ One-piece cylinder extensions can be installed easily at the job site to accommodate a variety of trench widths.
- ▼ Cylinder oversleeves are standard, provide extra strength, protect cylinders.
- ▼ Bleed-off ports eliminate over-extension of cylinders to increase the safety factor.
- ▼ Hinged design allows for fast knock-down and transport.



## Quick, easy, simple way to shore a trench; One-Person installation and removal from above ground

### INSTALLATION IS FAST, EASY, SAFE



Position shore at edge of trench. Connect hydraulic hose line to fitting.



Drop shore into trench at desired height.



Pump to minimum pressure of 750 psi. Disconnect hose from fitting using release tool.

### REMOVAL IS QUICK AND SIMPLE



Release hydraulic shoring fluid at fitting using release tool.



Pull shore assembly from trench using both release and removal hook.



Complete shore assembly folds flat for portability to next location.

# Wide selection of cylinders and rails available to meet your needs

## 4 Sizes of Standard Duty Rails

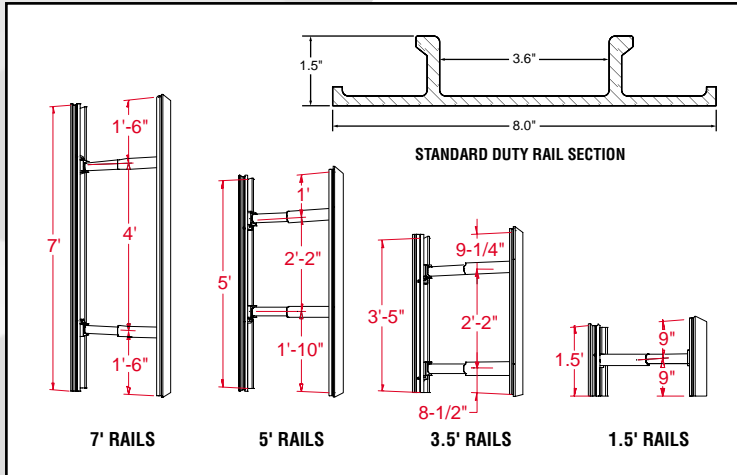

Professional Engineer certified for use in A, B, and C-60 soil. Meets or exceeds OSHA requirements.



## 7 Sizes of Heavy Duty Rails

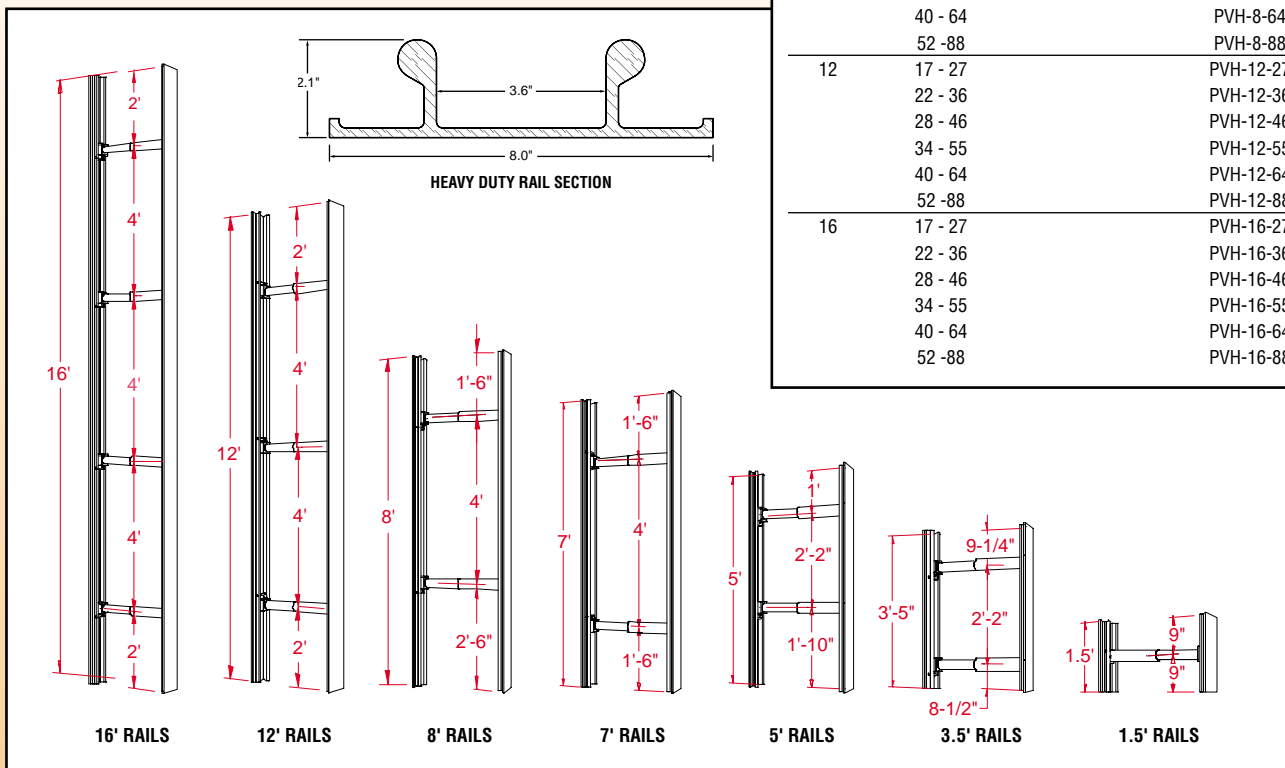

## Standard and Heavy Duty Rails to suit job conditions

RAIL LENGTH FEET	CYLINDER WIDTH IN INCHES	STANDARD DUTY MODEL	WEIGHT POUNDS	HEAVY DUTY MODEL	WEIGHT POUNDS
1.5	17 - 27	PVS-1.5-27	20	PVH-1.5-27	28
	22 - 36	PVS-1.5-36	24	PVH-1.5-36	30
	28 - 46	PVS-1.5-46	26	PVH-1.5-46	32
	34 - 55	PVS-1.5-55	28	PVH-1.5-55	34
	40 - 64	PVS-1.5-64	30	PVH-1.5-64	40
	52 - 88	PVS-1.5-88	36	PVH-1.5-88	44
3.5	17 - 27	PVS-3.5-27	44	PVH-3.5-27	50
	22 - 36	PVS-3.5-36	50	PVH-3.5-36	54
	28 - 46	PVS-3.5-46	56	PVH-3.5-46	62
	34 - 55	PVS-3.5-55	60	PVH-3.5-55	66
	40 - 64	PVS-3.5-64	68	PVH-3.5-64	74
	52 - 88	PVS-3.5-88	76	PVH-3.5-88	82
5	17 - 27	PVS-5-27	54	PVH-5-27	62
	22 - 36	PVS-5-36	60	PVH-5-36	66
	28 - 46	PVS-5-46	64	PVH-5-46	72
	34 - 55	PVS-5-55	70	PVH-5-55	78
	40 - 64	PVS-5-64	76	PVH-5-64	85
	52 - 88	PVS-5-88	86	PVH-5-88	92
7	17 - 27	PVS-7-27	64	PVH-7-27	78
	22 - 36	PVS-7-36	70	PVH-7-36	82
	28 - 46	PVS-7-46	74	PVH-7-46	90
	34 - 55	PVS-7-55	80	PVH-7-55	100
	40 - 64	PVS-7-64	88	PVH-7-64	106
	52 - 88	PVS-7-88	98	PVH-7-88	110
8	17 - 27			PVH-8-27	90
	22 - 36			PVH-8-36	94
	28 - 46			PVH-8-46	98
	34 - 55			PVH-8-55	100
	40 - 64			PVH-8-64	110
	52 - 88			PVH-8-88	118
12	17 - 27			PVH-12-27	132
	22 - 36			PVH-12-36	138
	28 - 46			PVH-12-46	146
	34 - 55			PVH-12-55	152
	40 - 64			PVH-12-64	162
	52 - 88			PVH-12-88	176
16	17 - 27			PVH-16-27	174
	22 - 36			PVH-16-36	184
	28 - 46			PVH-16-46	196
	34 - 55			PVH-16-55	202
	40 - 64			PVH-16-64	216
	52 - 88			PVH-16-88	234

## Cylinder Extension System broadens your work range

NORMAL CYLINDER RANGE IN INCHES	RANGE IN INCHES (WITH EXTENSION)	DESCRIPTION	MODEL NUMBER
17 - 27	28 - 38	11" EXTENSION	PEX 27-11
17 - 27	39 - 49	22" EXTENSION	PEX 27-22
17 - 27	50 - 60	33" EXTENSION	PEX 27-33
22 - 36	33 - 47	11" EXTENSION	PEX 36-11
22 - 36	44 - 58	22" EXTENSION	PEX 36-22
22 - 36	55 - 69	33" EXTENSION	PEX 36-33
28 - 46	43 - 61	15" EXTENSION	PEX 46-15
28 - 46	58 - 76	30" EXTENSION	PEX 46-30
28 - 46	73 - 91	45" EXTENSION	PEX 46-45
34 - 55	52 - 73	18" EXTENSION	PEX 55-18
34 - 55	70 - 91	36" EXTENSION	PEX 55-36
34 - 55	88 - 109	54" EXTENSION	PEX 55-54
40 - 64	61 - 85	21" EXTENSION	PEX 64-21
40 - 64	82 - 106	42" EXTENSION	PEX 64-42
40 - 64	96 - 120	56" EXTENSION	PEX 64-56
52 - 88	76 - 112	24" EXTENSION	*PEX 88-24
52 - 88	94 - 132	42" EXTENSION	*PEX 88-42
52 - 88	108 - 144	56" EXTENSION	*PEX 88-56

\*REQUIRES STEEL OVERSLEEVES

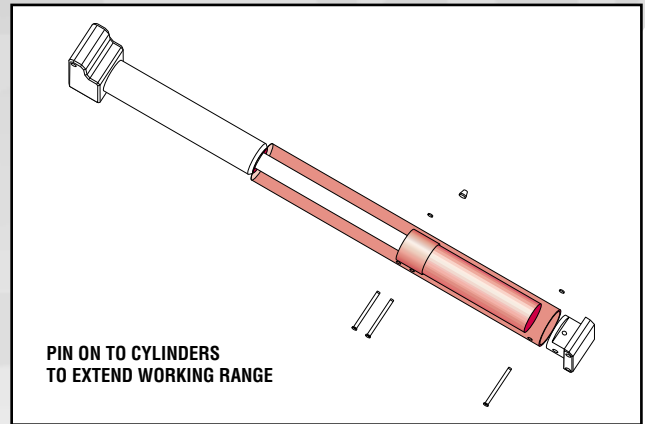

## See Your PRO-TEC distributor for details on these quality engineered products



Modular Trench Shields



Slide Rails



High Clearance Arch



Steel Trench Shields



ATS Aluminum Shield

### State-of-the-art manufacturing produce industry's strongest shielding and shoring

Modern manufacturing facilities equipped with state-of-the-art fabricating equipment help produce the industry's strongest shielding and shoring.

### Dedicated shielding and shoring engineering services

PRO-TEC engineering and consulting services are available to help solve your shielding and shoring problems. CAD drawings are provided with special project quotations.



P.O. Box 130 • 1298 Lipsey Dr. • Charlotte, MI 48813  
 Phone: (517) 541-0303 or 1-800-292-1225  
 Fax: (517) 541-0329  
[www.pro-tecequipment.com](http://www.pro-tecequipment.com)